

# Predator Front Rudder Servo Mount Kit

#HC6002

The front rudder servo mount kit is an upgrade for the glow & gas series Predator helicopter kits. Moving the rudder servo to the front keeps the rudder servo clean inside the canopy, moves the C.G. forward and eliminates the servo extension.

This mount kit requires:

#CN2294 Push-Pull Elevator Set

#HC6001-12 Metal Push-Pull Arm - Left Side

OR

#HC6001 Carbon Side Frame Conversion Kit.

## Step 1 Front Rudder Bellcrank Assembly

The tail bellcrank needs a M3x7 flanged bearing pressed into both sides. This is a tight and should be installed using a small press. Insert one bearing from one side then insert the M3x5x3 steel spacer, followed by the second ball bearing. Insert two short steel balls into both ends of the bellcrank (on the side with the boss), using L242 Blue threadlock. Looking at the carbon rudder mount, insert one M3x20 socket cap screw through the left side (as shown) and thread the M3 hex nut and tighten against the mount using L242 Blue threadlock. Slide one M3x5x0.5 micro washer, the bellcrank assembly, one more M3x5x0.5 micro washer and secure using one M3 locknut. Tighten the locknut until there is no axial movement but the bellcrank pivots smoothly.

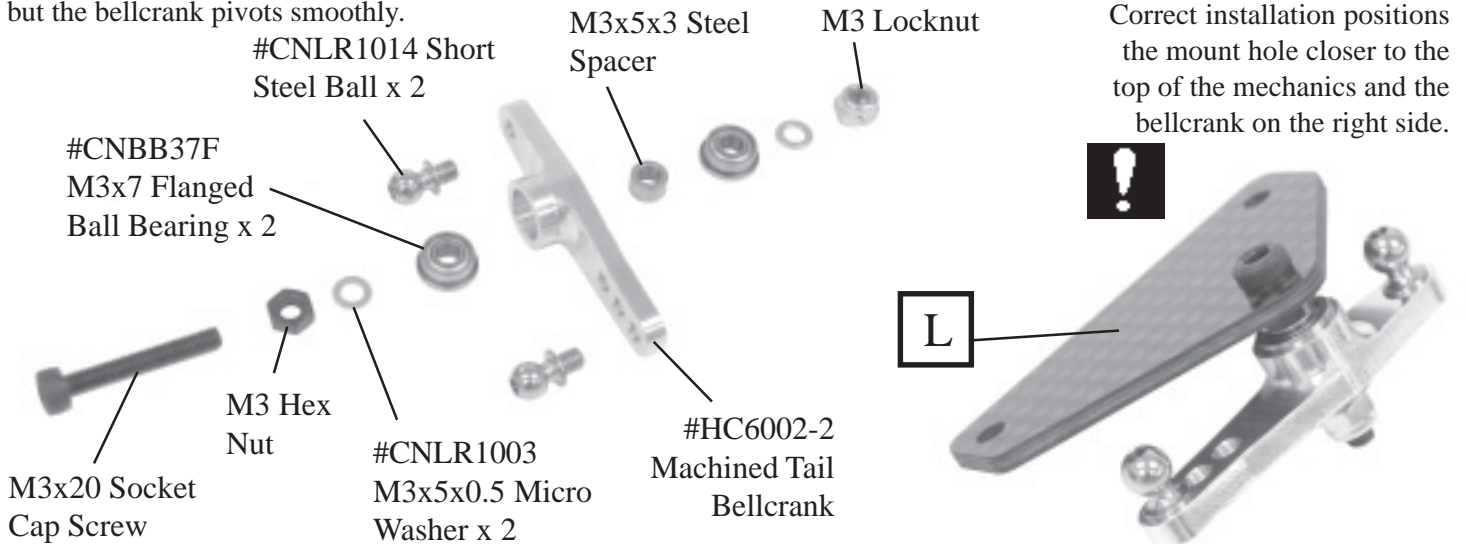

## Step 2 Tail Bellcrank Mount

Align the tail bellcrank mount overlapping the holes for the tail transmission and notice that the M3x20 socket cap screw does touch the tail transmission. Some slight grinding is necessary on the transmission or the screw head to avoid stressing the mount.

Install the mount using one M3x12 button head cap screw inserted into the top hole and one M3x10 socket cap screw with M3 flat washer into the bottom hole using L242 Blue threadlock.

M3x10 Socket Cap Screw & M3 Flat Washer

M3x12 Button Head Screw

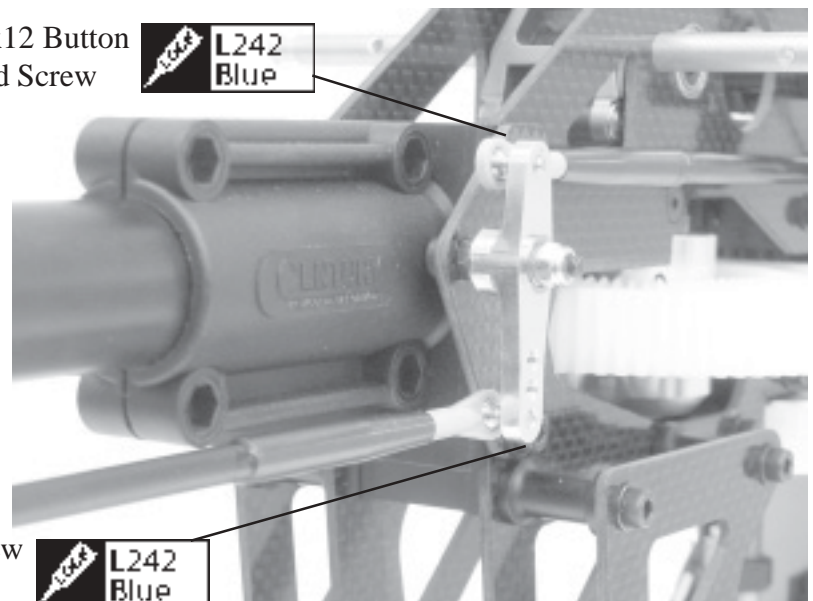

### Step 3 Rudder Pushrod Setup

Reposition if necessary the steel ball on the rudder servo horn at a position of 13mm from the center of the servo. This will create a 1 to 1 relationship between the rudder servo and the input on the tail bellcrank. Center the sub and regular trims for the rudder and press the servo horn onto the servo, securing with the servo screw. The final distance for the front carbon pushrod is ~188mm center to center. Measure, cut and bond the machined pushrod ends to achieve this distance.

Similarly, bond one machined end of the rear carbon pushrod and attach to the tail bellcrank. Slide on one or two of the tail pushrod support guides and position them on the tail boom. Align the carbon pushrod to the tail bellcrank, measure, cut and bond the machined pushrod end with ball link to achieve the 5° degrees (roughly center the pitch plate between the tail gear box and the tail rotor hub) of tail rotor blade pitch.

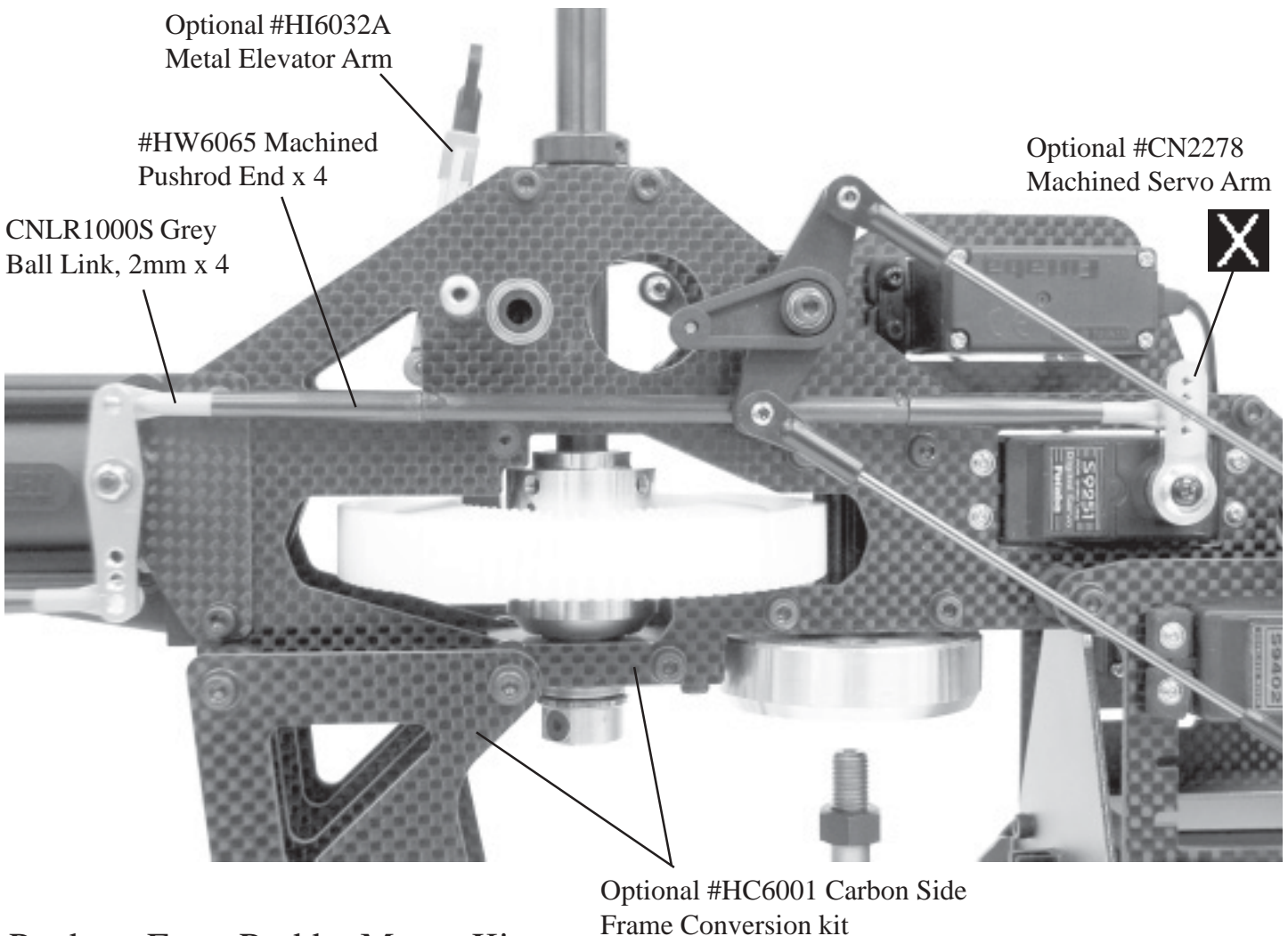

### Predator Front Rudder Mount Kit Replacement Parts

HC6002-1	Carbon Rudder Bellcrank Mount
HC6002-2	Machined Tail Bellcrank - Purple
HI3205	Servo Mount Tabs (10)
HI6106	Tail Pushrod Guides (2)
HI6145	Heavy Duty Ball Links
HW6065	Carbon Pushrod w/ End Fittings
CNLR1000S	2mm Ball Links - Grey (10)
CNLR1014	Short Steel Balls M3 (2)
CNM37F	M3x7 Flanged Bearings (2)

Century Helicopter Products  
1740 - C Junction Ave.  
San Jose, CA 95112 USA  
Tel: 408-451-1155  
www.centuryheli.com